

**NOTES:-**

1. WELD SIZE SHOULD BE 15mm AT ALL WELDING PLACES.
2. ALL DIMENSIONS ARE OBTAINED BY MEASUREMENT OF THE PART AND BASED ON DRG. 085-001-00-023 (USSR DRG. NO. K-352190, BSL. ARC. NO. UT-E 89585)
3. THIS DRG. IS CORRESPONDS TO USSR DRG. NO. K-352138 WHICH IS NOT AVAILABLE

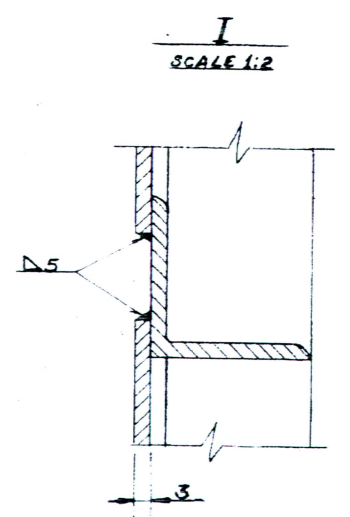

DRG. NO.	POS.	DESCRIPTION	QTY	UNIT	TOTAL	MATERIAL	REMARKS
				NT. IN KG.			
		WELD METAL		4.5	4.5	M. 8	
	8	PLATE 1535x1400x3	1	50.25	50.25	St-425 IS:226-69	
	7	PLATE 1535x1415x3	1	50.80	50.80	St-428 IS:226-69	
	6	PLATE 1535x700x3	1	25.1	25.1	St-428 IS:226-69	
	5	ANGLE 65x65x5, L=1545	2	18.0	36.0	STRU-STEEL	
	4	ANGLE 65x65x5, L=720	2	3.5	7.0	STRUC. STEEL	
	3	ANGLE 65x65x5, L=735	1	3.7	3.7	-DO-	
	2	ANGLE 65x65x5, L=730	2	3.6	7.2	-DO-	
	1	ANGLE 65x65x5, L=1545	6	7.6	45.6	-DO-	

POS.	DESCRIPTION	QTY	UNIT	MATERIAL	G.A. DRG.	SC.	DRG. NO.
7	SECTION SIDE SHIELD	1	23015	ASSLY	085-001-00-023	1:20	085-001-00-024

		<b>BOKARO STEEL LIMITED</b>	
SHOP	T. P. P. & T. B. S.		
UNIT	BOILER		
DESCRIPTION OF DRAWING	DETAILS OF AIR HEATER SECTION EXTREME OF BOILER T <sub>1</sub> -155, D=220 7/8, P=100 1/2, t=5.40		
REVISIONS	DRAWN	S. PRASAD 12/5	DATE MAY-75
	CHECKED	B. RAM	SCALE
	TRACED		
	SUBMITTED		085-001-00-024
	APPROVED		

0.5A1