

ALL OVER

TECHNICAL INSTRUCTIONS

1. SURFACE A, B AND C TO BE CHECKED WITH TEMPLATE FOR THEIR INTERCHANGIBILITY.
2. A CLEARANCE OF UP TO 2mm IS ALLOWED BETWEEN SURFACE A AND TEMPLATE.
3. ALLOWED TO MAKE THE DETAIL FROM A MM-STEEL AS PER IS: 276-61. OR latest version.

NOTE

1. THIS DRG. IS BASED ON DRG. NO - 2-31868
2. ALSO USED FOR DPR NO 85/004

ORIGINAL DOCUMENT
 SUPPLIER DRG. NO. HMB No. 140103-18
 BSL-ARCH. NO. UT-5-H 85.001

POS NO	DESCRIPTION	QTY	UNIT	STEEL	DRG. NO
-	SHELL LINER (WEDGE SIDE)	-	102.2 T B/L	651752355	085.003
-	DESCRIPTION	-	UNIT	MATERIAL	G.A. DRG. NO

SHOP		BOKARO STEEL LIMITED	
UNIT		T.P.P.	
DESCRIPTION		DRUM OF COAL CRUSHING BALL MILL.	
D.R. NO.		0851003	
REVISIONS OF DRAWING	DRAWN	CHECKED	DATE
	S.R. SINGH	M.K. PRINAK	OCT 76
			1945
			085.003-04.001
			-D-

Handwritten signature and date: 12.11.21

~ ALL OVER

TECHNICAL INSTRUCTIONS

1. UNSPECIFIED CASTING RADIUS TO BE R5 mm.
2. ALLOWED TO MAKE THE DETAIL FROM A.M.M. STEEL AS PER IS: 276-68.

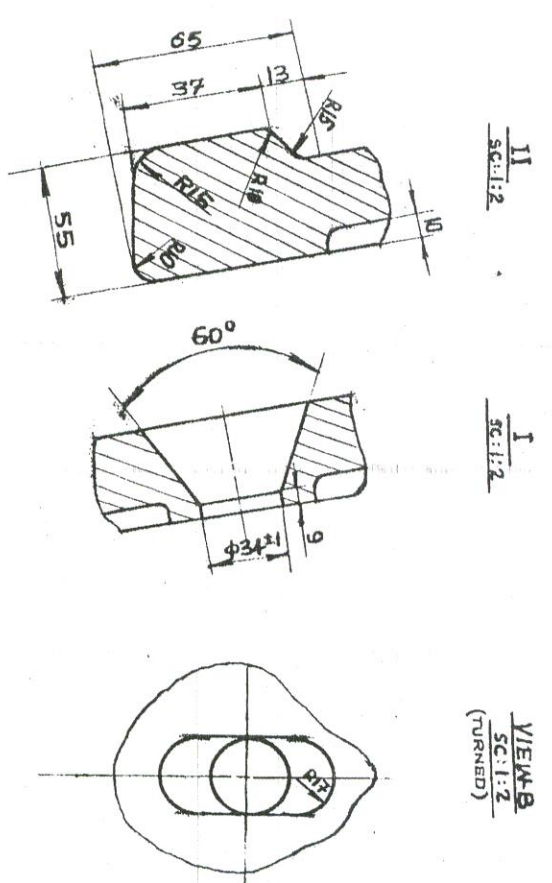
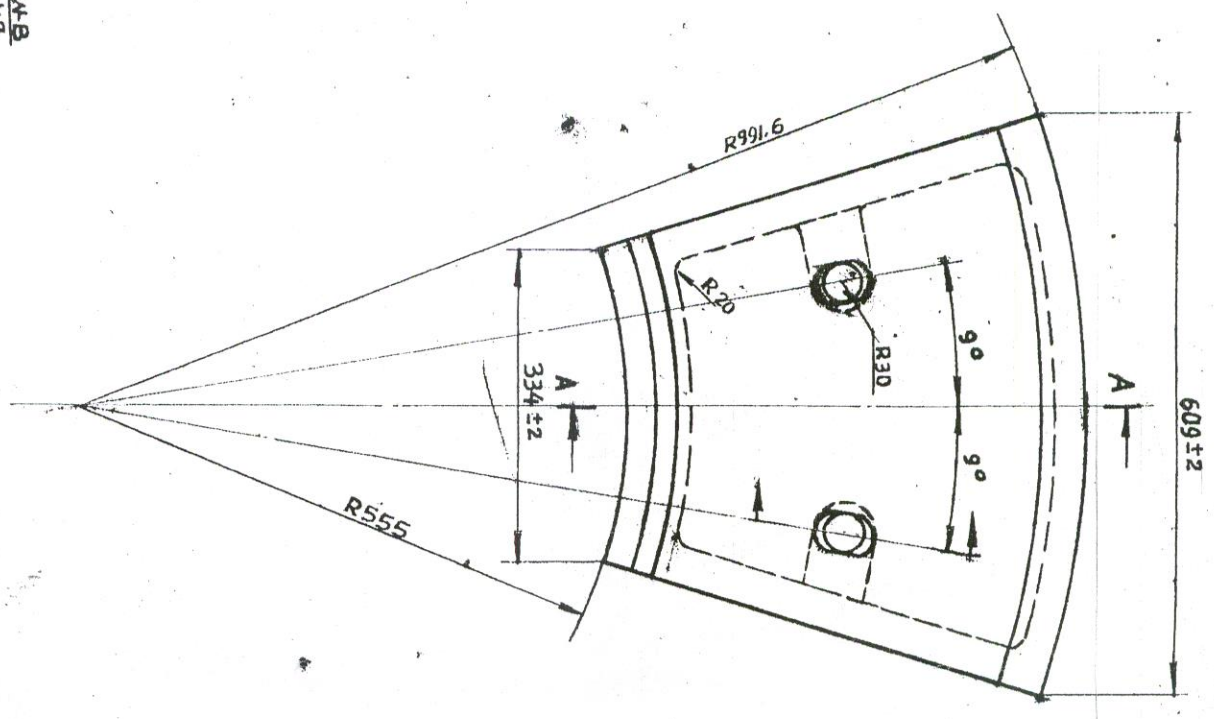
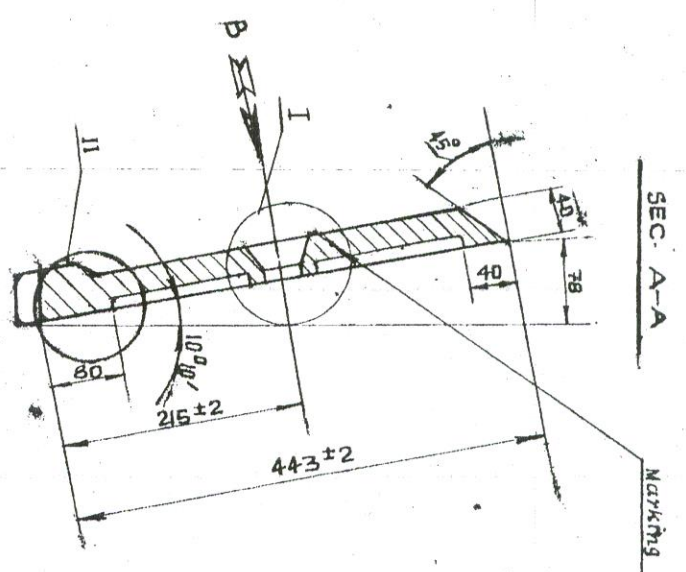

ALSO USED FOR 085/004.

Handwritten signature and date: 07/10/21

POS. NO.	DESCRIPTION	QTY	WT. Xg	MATERIAL	SCALE	DRG. NO.
-	END FACE LINER (BOTTOM)	-	60	STEEL/JAN. 1401.03.01	1:5	085-003-00-D/140
				COAL CRUSHING		

ORIGINAL DOCUMENT	
SUPPLIER'S NAME & NO.	HMB 14-01-03-25
B. S. L. ARCH. NO.	
SHD P	T. P. P.
UNIT	BOKARO STEEL LIMITED
DESCRIPTION OF DRAWING	DRUM OF COAL CRUSHING MILL DPR. 85/003
REVISIONS	DETAIL OF END FACE LINER OF COAL CRUSHING DRUM.
TRACED	K. MAHARAJ
CHECKED	S. B. BOSE
SUBM.	
RECOM.	
APPR.	
	DATE APR. 26
	SCALE 1:5
	085.003.00.014-D

BASED ON DRG. NO 3-6181942

0 SHI

CI-510-00-500-580

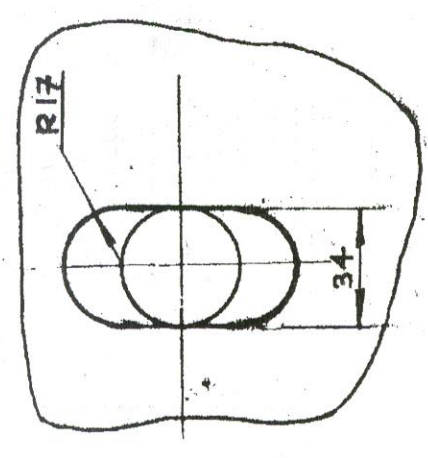
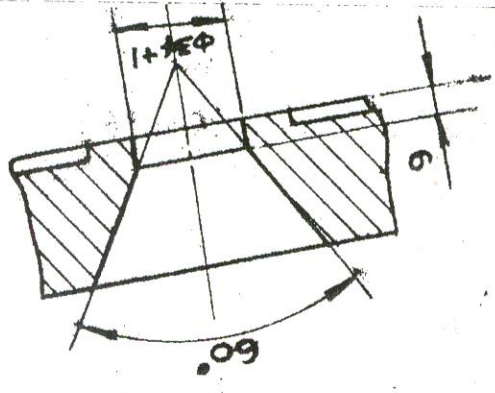
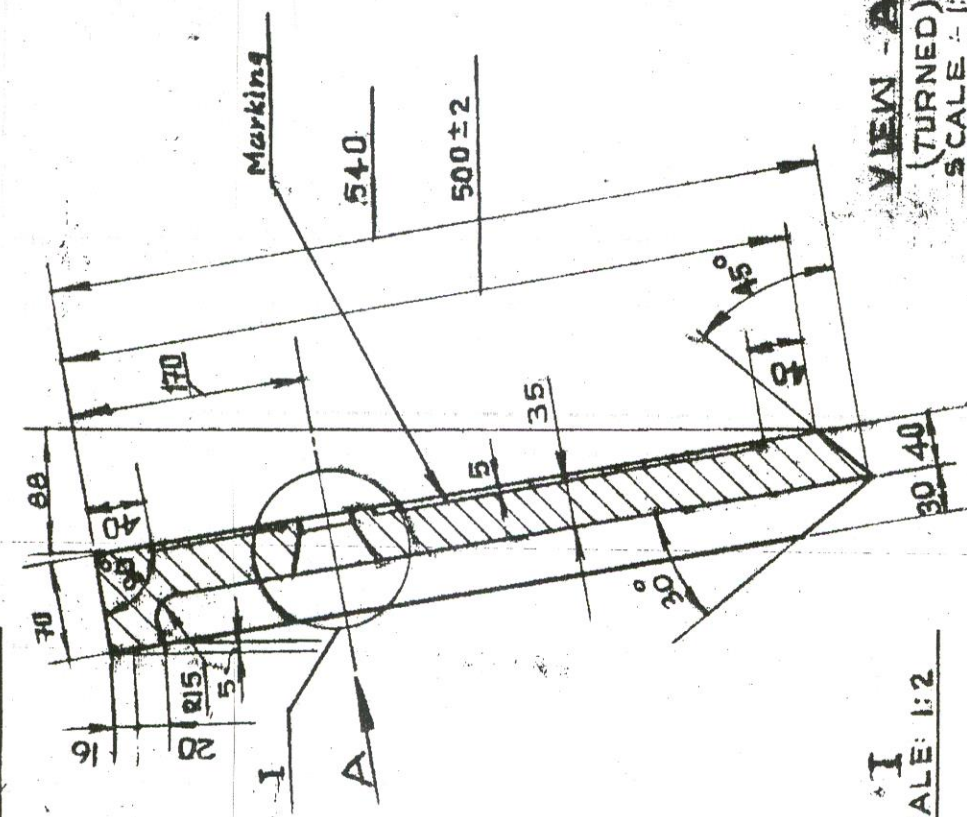
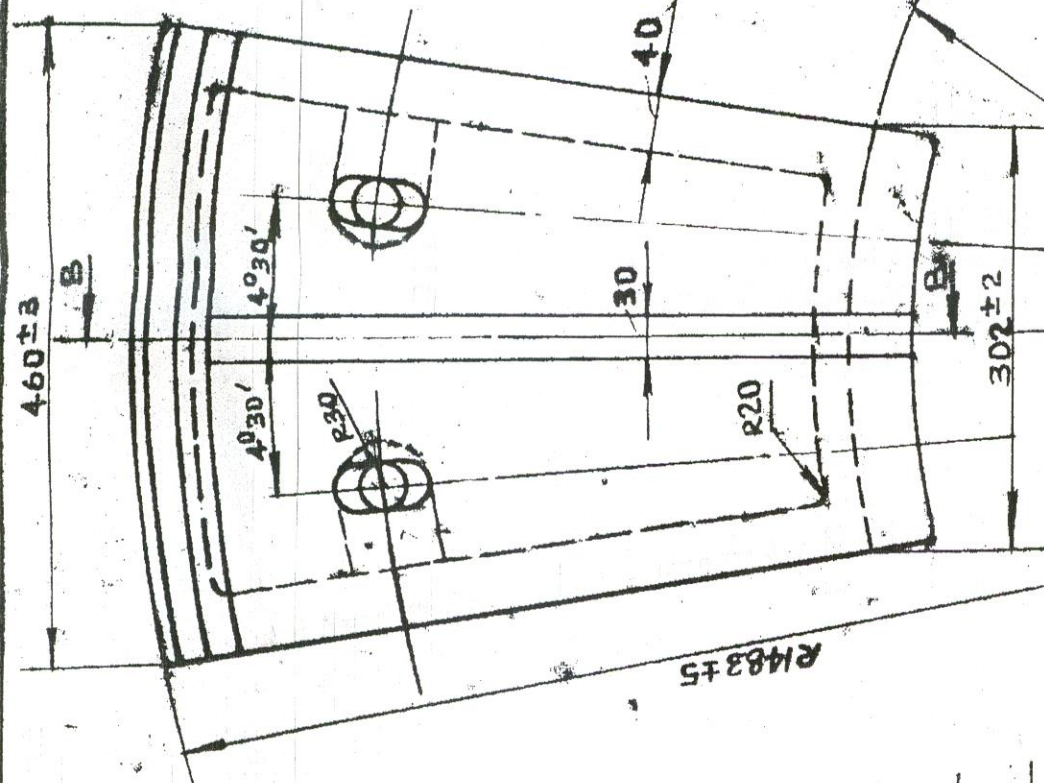

VIEW - A
(TURNED)
SCALE: 1:2

ALSO USED FOR 085/004

Handwritten signature

WALL OVER

TECHNICAL INSTRUCTIONS

1. UNSPECIFIED CASTING RADII TO BE 5mm
2. ALLOWED TO MAKE THE DETAIL FROM A MK STEEL AS PER IS:276-63

POS NO	DESCRIPTION	QTY	WT. KG	MATERIAL	G.A. DRG. NO	SC.	DRG. NO
-	END FACE LINER (TOP)	-	58.4	STEEL 13.14 01.03 00 GOST 7523-55	14 01.03 00	1:5	085.003.00.013-D

BOKARO STEEL LIMITED		T. P. P.	
UNIT	DRUM OF COAL CRUSHING BALLMILL 085/003		
DESCRIPTION OF DRAWING	DETAIL OF END FACE LINES OF COAL CRUSHING DRUM		
REVISIONS	TRACED	K. MAHARAJ	9.4
	CHECKED	S. B. BOSE	
	SUBM.		
	RECOM.		
	APPR.		
			DATE APR. 76
			SCALE 1:5
			085.003.00.013 - D

ORIGINAL DOCUMENT
SUPPLIER'S NAME (DRG) HMB1401.03.24
B. S. L. ARCH. NO

BASED ON DRG NO 3-54582 M

0.25/1

BASED ON DRG. NO. 3-61144N.

REF. DOCUMENTS

FROM HMB(HEC) USSR DRG

No-14 01.03.19 ARCHNO UT-191-H 85023.

APPROVED				
RECOMMEND				
SUBMITTED				
CHECKED	S.N. Pd. 066	10/25	JUNE 87	85.003/ B-0387
TRACED	V. PRASAD	10/25	SC-4:2	B-0388
VISIONS				
DRAWING				
DESCRIPTION				
DETAILS OF BALL MILL				
T.P.P. - T.B.S (C)				
BOILER (085.003)				
BOKARO STEEL PLANT				

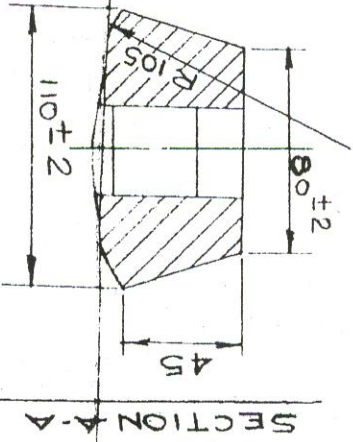
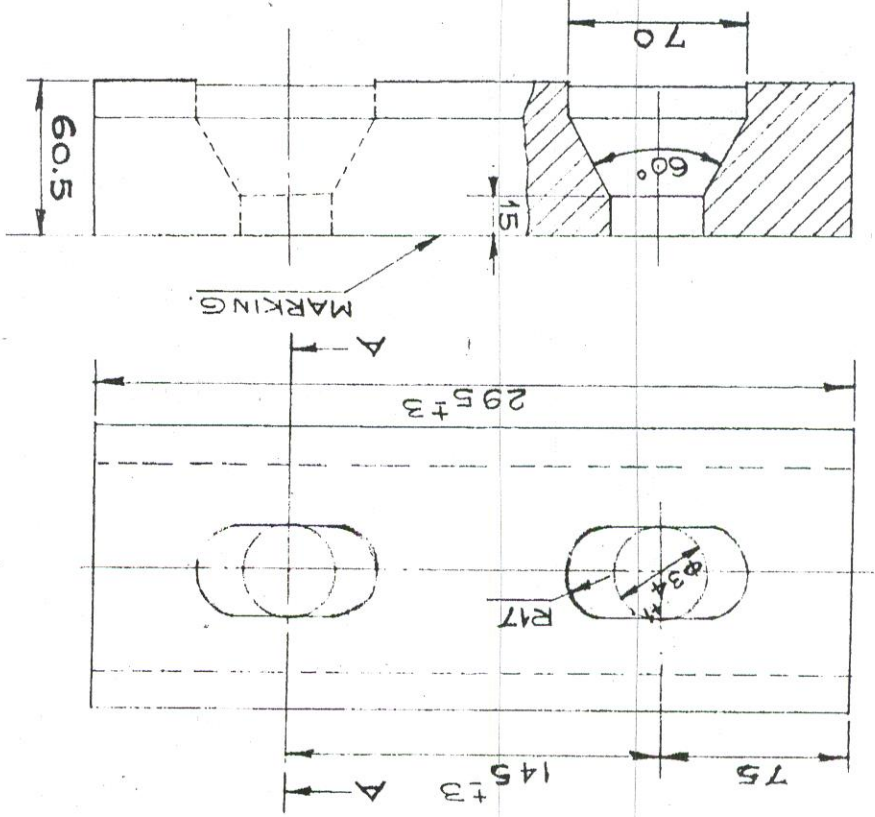

TECHNICAL INSTRUCTIONS.

- UNSPECIFIED CASTING RADII TO BE 5mm.
- ALLOWED TO MAKE THE DETAILS FROM A.M. STEEL AS PER IS: 276-63.

Handwritten signature and date: 3/4/21

8850-8/E00580

BASED ON DRG. NO. 3-61144N.

REF. DOCUMENTS TRACED FROM HMB(HEC)

USE DRG NO-1401.03.17. ARCHNO. UT-191-H 85023.

POS DESCRIPTION	QTY	UNIT	MATERIAL	G.A.	SC DRG NO
WEDGE L:400	1	15	STEEL	L132	85.003/ B-0387
SCALE: 1:2					

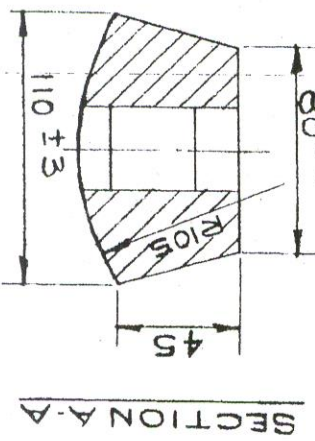
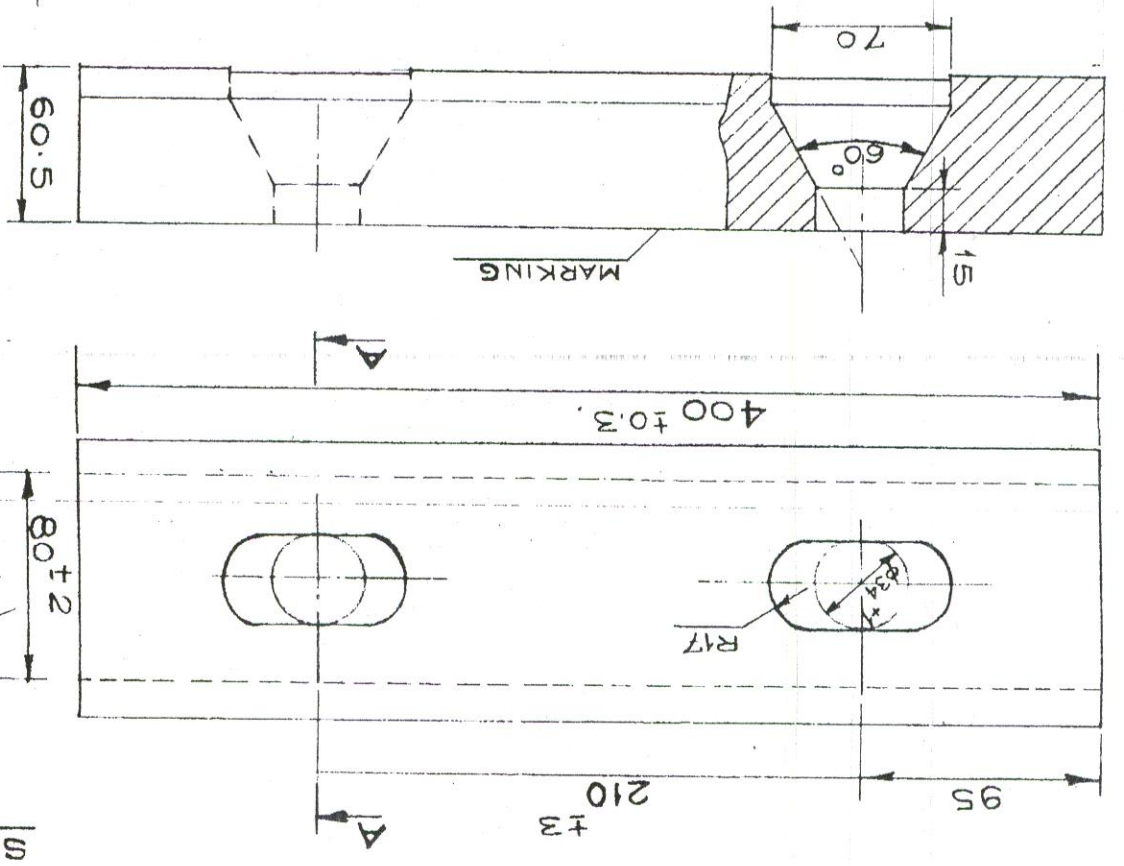

TECHNICAL INSTRUCTIONS.

- UNSPECIFIED CASTING RADII TO BE 5mm.
- ALLOWED TO MAKE THE DETAILS FROM A.M. STEEL AS PER IS: 276-63.

Handwritten signature and date: 3/4/21

~ ALL OVER

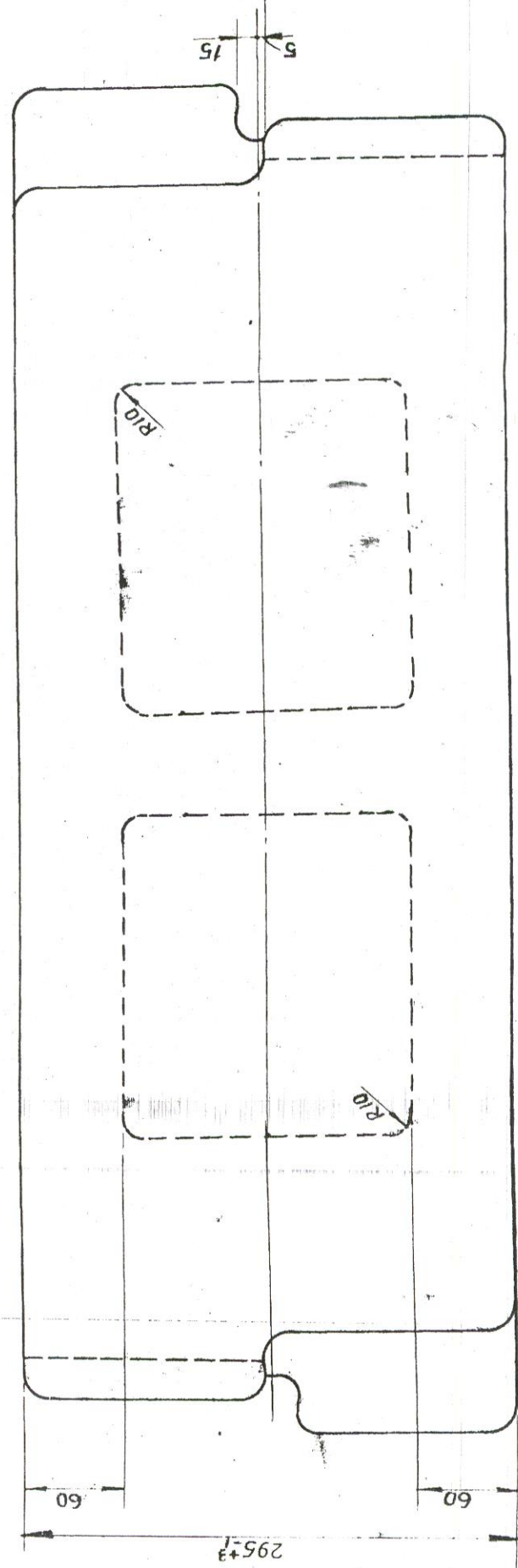
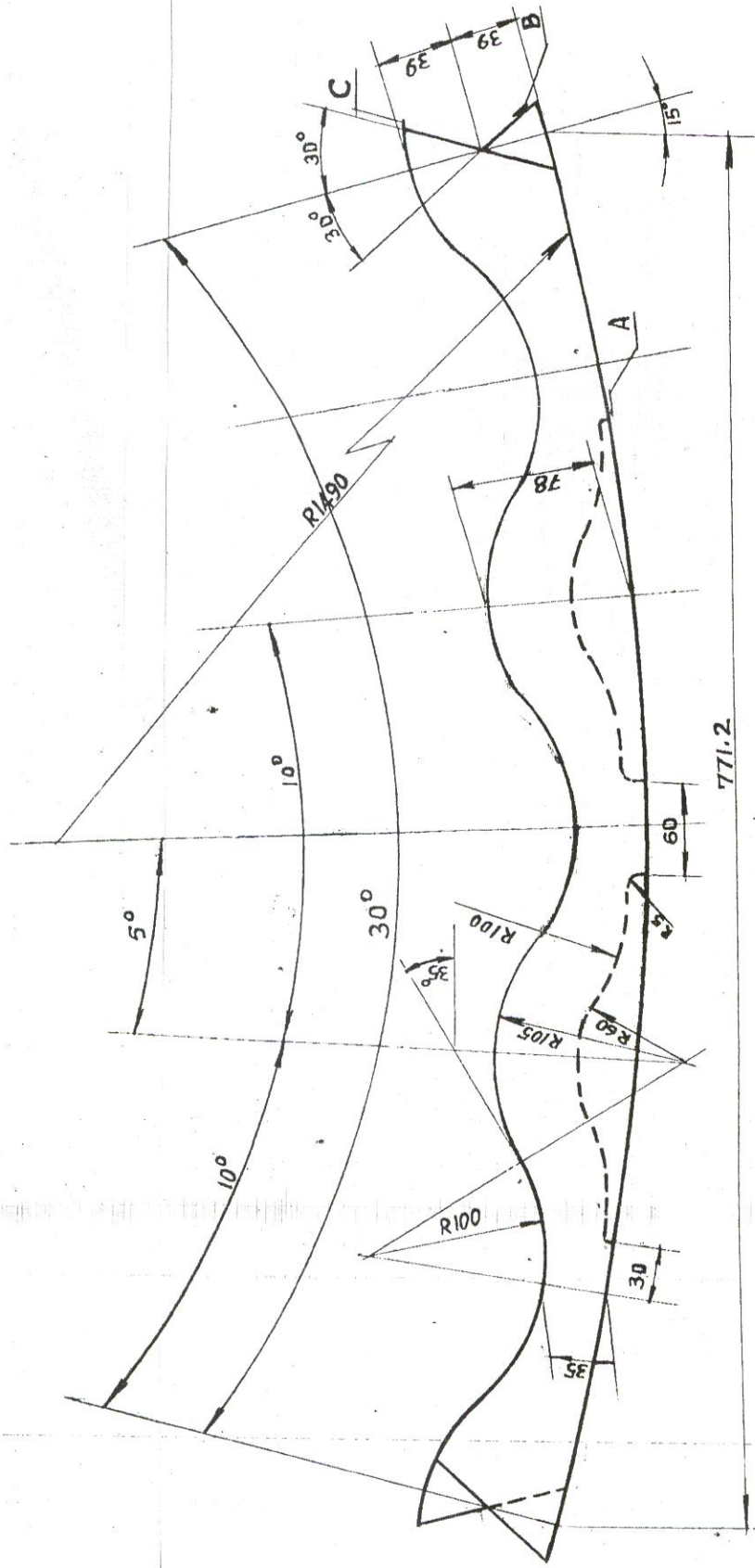

TECHNICAL INSTRUCTIONS

1. SURFACE A AND C TO BE CHECKED WITH TEMPLATE FOR THEIR INTER CHANGEABILITY.
2. A CLEARANCE OF UPTO 2MM IS ALLOWED BETWEEN SURFACE A AND TEMPLATE.

REF. DOCUMENT HMB DRG. NO. 1401.03.01. AND BSL ARCH. NO. UT-S-H/65004.

—	SHELL LINER	—	86	AMH STEEL	14-01-03-00	125	085.003.00
POS No.	DESCRIPTION	QTY.	WT. kg.	MATERIAL	G. ASSLY. SCHE. DRG. NO.		004

BOKARO STEEL LIMITED							
SHOP T P P							
UNIT DRUM COAL CRUSHING BALL MILL DPR NO. 85/0034							
DESCRIPTION SHELL LINER							
OF DRAWING REVISIONS	DRAWN	TRACED	CHECKED	SUBMITTED	APPROVED	DATE	JUN '73
	K. MAHARAJ	K. MAHARAJ	K. N. JHA			12/6/73	SCALE 1:2.5
							085.003.0004

Handwritten signature/initials in blue ink.

0541

085.003.00.002

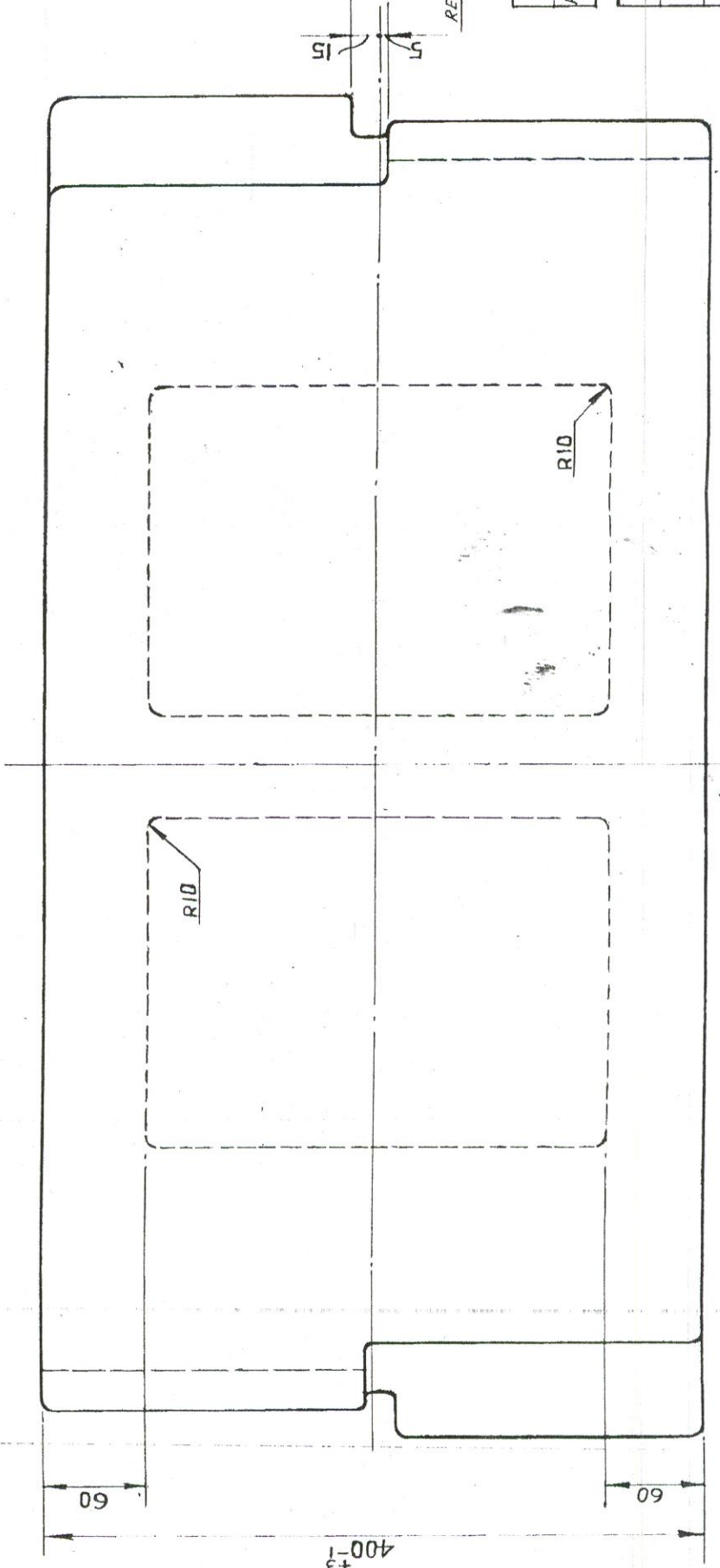
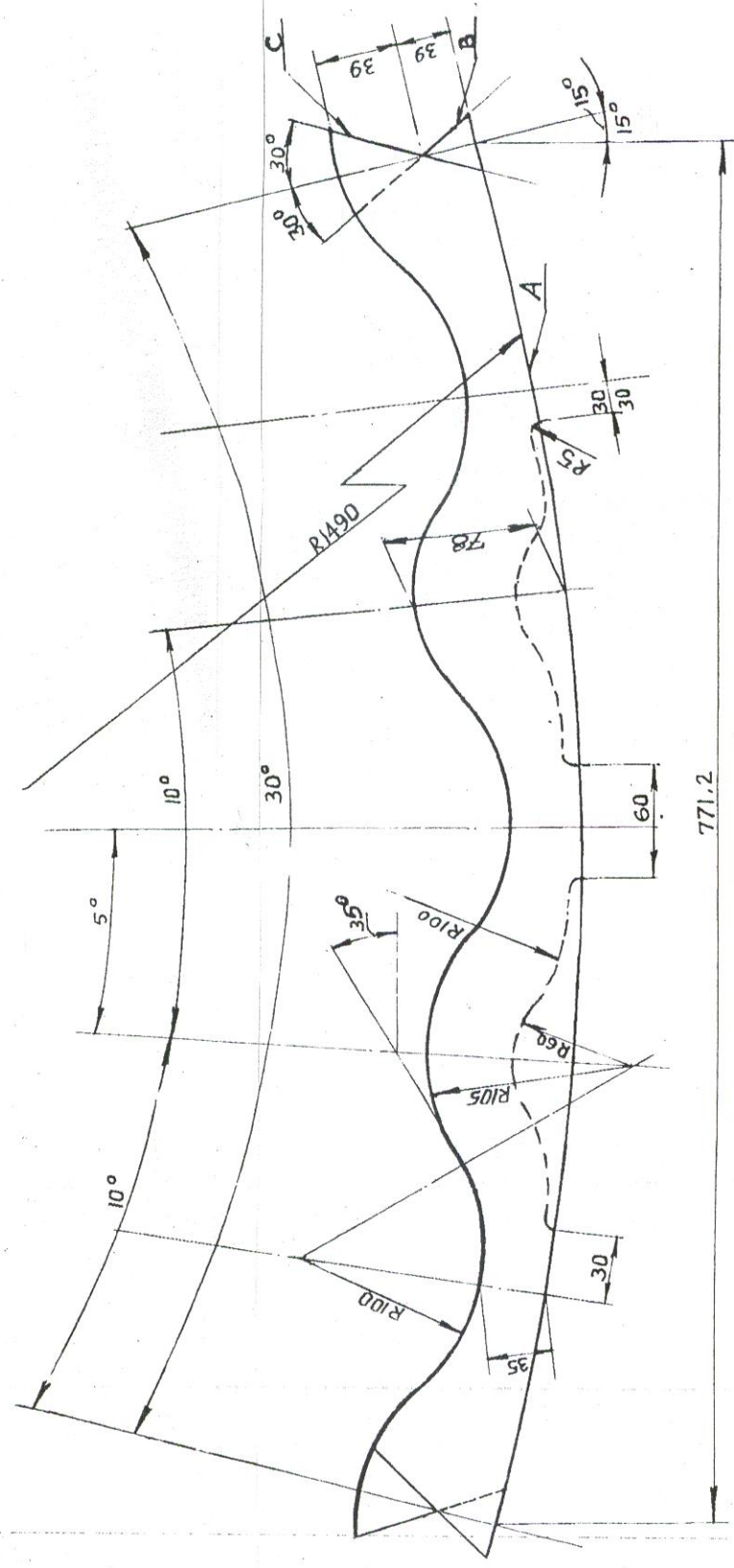

[Handwritten signature]
21/12/75

TECHNICAL INSTRUCTIONS

1. SURFACE A, B AND C TO BE CHECKED WITH TEMPLATE FOR THEIR INTERCHANGEABILITY.
2. CLEARANCE OF UPTO 2MM IS ALLOWED BETWEEN SURFACE A AND TEMPLATE.

REF DOCUMENT HMB DRG. NO 1401-03.02 AND BSL ARCH. NO UT. S. H/85003

POS NO	SHELL LINER	QTY	WT. KG.	MATERIAL	G. A. DRG. NO.	SC	DRG. NO.
-	119			MM/STEEL	1401-03.00	1:2	5085.003.00.002

BOKARD STEEL LIMITED	
SHOP	T. P. P.
UNIT	COAL CRUSHING BALL MILL DPR NO 085/003
DESCRIP-TION OF DRAWING	
REVISION	DRAWN
	TRACED K. MAHARAJ
	CHECKED B. RAM
	SUBMITTED
	APPROVED
DATE	JUN 75
SCALE	1:2.5
	085.003.00.002

ALSO USED FOR DPR NO 085/004

OB5.003.00.005A

NO ALL OVER

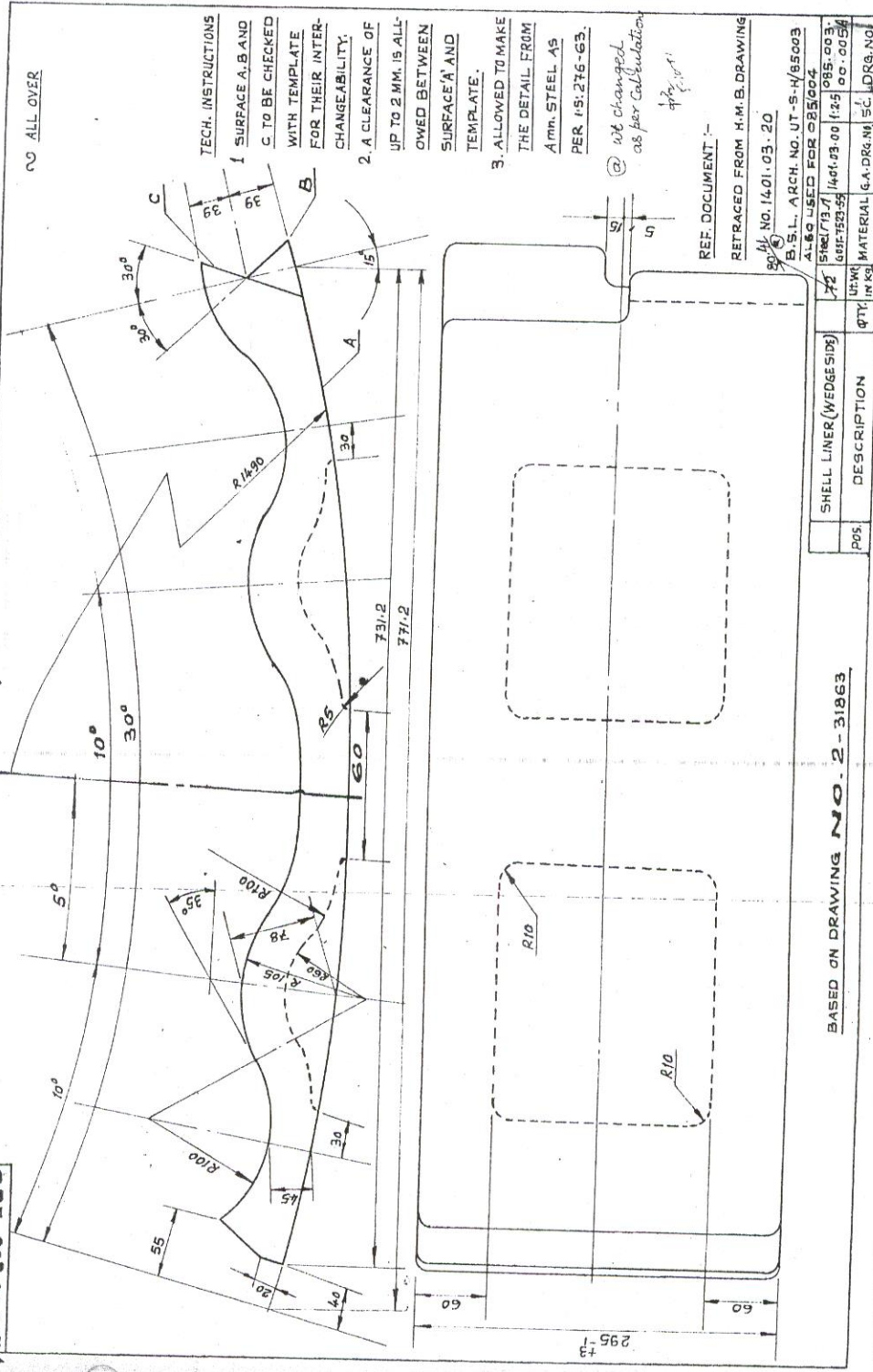

TECH. INSTRUCTIONS
 1. SURFACE A, B AND C TO BE CHECKED WITH TEMPLATE FOR THEIR INTER-CHANGEABILITY.
 2. A CLEARANCE OF UP TO 2 MM. IS ALLOWED BETWEEN SURFACE A AND TEMPLATE.
 3. ALLOWED TO MAKE THE DETAIL FROM 1mm. STEEL AS PER IS: 276-63.

wt changed as per calculation
 4/2/04

REF. DOCUMENT :-
 RETRACED FROM H.M.B. DRAWING NO. 1401.03.20
 B.S.L. ARCH. NO. UT-S-1/95003
 ALSO USED FOR 085.004
 SHEET NO. 1401.03.00 (25) 085.003
 085.003 085.003 085.003
 MATERIAL (S.A. DRG. NO) 50 (DRG. NO)

POS	DESCRIPTION	QTY	UNIT	MATERIAL (S.A. DRG. NO)	SC	DRG. NO
	SHELL LINER (WEDGESIDE)	1				

BASED ON DRAWING NO. 2-31863

Handwritten signature and date: 12/12/04