

POS.NO.-8

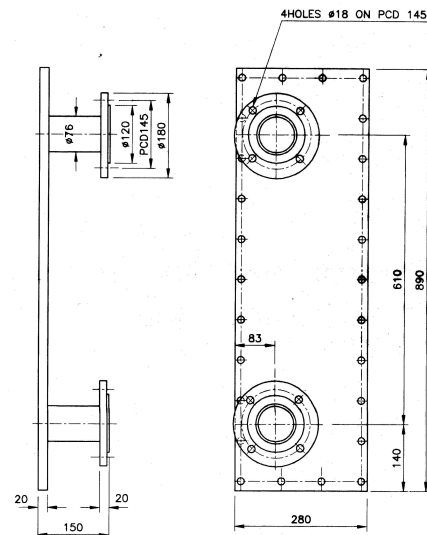

POS.NO.-9

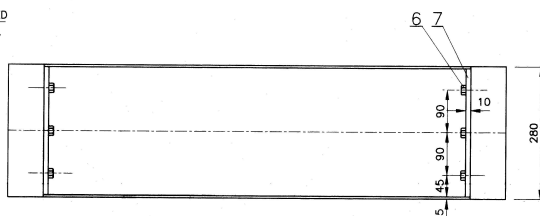
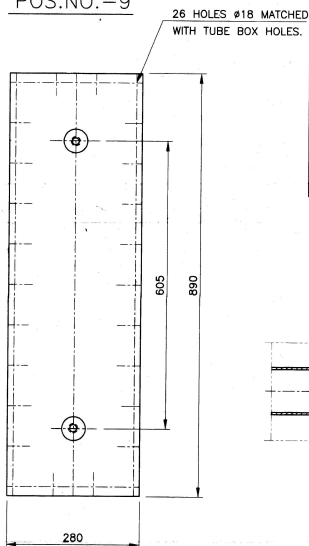

POS.NO.-1
(Wire Wound Fins)

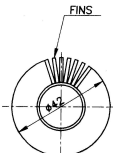
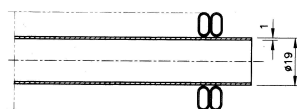

TECHNICAL REQUIREMENTS :

1. NOMINAL TEMPERATURE OF COOLING WATER : 30 °C
2. WATER QUANTITY : 10M³/Hr.
3. LOAD DISSIPATED : 48 KW
4. PRESSURE DROP OF WATER : 45 Pp
5. TEST PRESSURE : 6 Kg/Cm²
6. MAX. PERMISSIBLE WATER PRESSURE : 4Kg/cm²

NOTES

1. FOR TENDERING PURPOSE ONLY.
2. THE SUCCESSFUL TENDERER SHALL SUBMIT THE DETAIL MANUFACTURING DRAWINGS FOR APPROVAL.
3. REF. DRG NO. MV-36-01-101 Rev 03

AGREED TO:-

M. RUDRA
AGM(E)/ POWER PLANT

| DRG. NO. | POS. NO. | DESCRIPTION | QTY | UNIT | TOTAL WT. IN KG. | MATERIAL | REMARKS |
|----------|----------|---------------------------|-----|------|------------------|---------------------------------------|---------|
| | 9 | COVER (Revol. End) | 1 | - | - | F-410V8 IS-8062-9c | |
| | 8 | COVER (Revol. End) | 1 | - | - | F-410V8 IS-8062-9c | |
| | 7 | PLATE | 4 | - | - | F-410V8 IS-8062-9c | |
| IS-1364 | 6 | HEX. SCREW M10x25 | 12 | - | - | ISCL 6.8 F-1367-9a | |
| | 5 | LOWER COVER | 1 | - | - | F-410V8 IS-8062-9c | |
| | 4 | UPPER COVER | 1 | - | - | F-410V8 IS-8062-9c | |
| | 3 | TUBE BOX | 1 | - | - | F-410V8 IS-8062-9c | |
| | 2 | TUBE BOX | 1 | - | - | F-410V8 IS-8062-9c | |
| | 1 | COOLING TUBE #19x1.1L=940 | 93 | - | - | CUTTING SHEETS IS-1367-9a FINE-Copper | |

| POS. NO. | DESCRIPTION | QTY | UNIT | MATERIAL | ASSEMBLY DRG. NO. | SC. | DRG. |
|----------|-------------|-----|------|----------|-------------------|-----|------|
| | AIR COOLER | 1 | - | ASSLY. | | M63 | M63 |

| BOKARO STEEL PLANT | | | | | | | |
|------------------------|-----------|---|----------|--|--|--|--|
| SHOP | | C.P.P | | | | | |
| UNIT | | BOILER FEED PUMP MOTOR | | | | | |
| DESCRIPTION OF DRAWING | | AIR COOLER (FOR 2300W, 6.6KV, B.F.P. MOTOR) | | | | | |
| DRAWN | NASEEM | DATE | APPROVED | | | | |
| CHECKED | H.RANSARI | DATE | APPROVED | | | | |
| SUBMITTED | B. RAM | DATE | APPROVED | | | | |
| RECOMMENDED | | DATE | APPROVED | | | | |
| APPROVED | K.N.JHA | DATE | APPROVED | | | | |

